



## HT8 MULTI-SPEED DRUM FLOOR SANDER

The HT8 Multi-Speed is the next generation floor sander for hire and rental, contractor and professional markets. The world's only multi-speed floor sander brings a new dimension to the sanding of all types of wooden floors from parquet to laminates. Versatile, reliable, intelligent - now everybody can sand any type of wooden floor to a perfect finish.

### Multi-Speed Control

Designed by Hiretech, the multi-speed control provides both on/off switching of the floor sander and the choice of four operating speeds in a simple, easy to use configuration. Additional functionality comes in the form of 'no volt start' that prevents accidental start-up when the power cord is connected to the power supply. Motor stall protection, operating within just 1.5 seconds of a stall event. Motor overload protection and run-time management provided by service indicator lights via the four speed-selector buttons.

For the do-it-yourself user, one of four drum speeds can be selected to match individual skill level - allowing the user to gain confidence before selecting the ideal speed for the job and application.

For the contractor and professional user the HT8 Multi-Speed is a versatile, powerful floor sander suitable for all types of jobs. The multi-speed control provides the range of performance, control and feel demanded by the skilled user to sand all types of floor to the perfect finish.



### Features

The HT8 is a high performance 200mm (8") drum floor sander that will level and sand all types of wooden floors, including parquet to a fine score free finish, suitable for finishing with today's modern waterborne lacquers and oils. The HT8 can also be used on a wide range of other surfaces including some types of decking, fibre board, cork and composition floors.

A powerful four brush motor drives a dynamically balanced sanding drum which is covered in a unique drum rubber. Completely self-contained with a high efficiency dust pickup, the HT8 breaks down into three simple component parts for easy transport. The high impact ABS injection moulded side guards and drum guard will not scar or scuff walls and protect the HT8 during transport.

The unique drum rubber resists abrasion and damage caused by exposed nails while providing the feel and touch needed to sand a fine, score free finish. Easily replaced in just 20 minutes the Hiretech drum rubber design minimises downtime and service costs.

Hiretech's patented<sup>1</sup> reversible clamp bar makes it easy for the user to fit abrasives, quickly and accurately. The clamp bar is a dropped forge design that will not bend or distort over time ensuring that the abrasive paper is clamped securely in place at all times. The HT8's unique lifting fin assembly lifts the clamp bar clear of the drum making it a simple, two handed job to remove and fit abrasives.

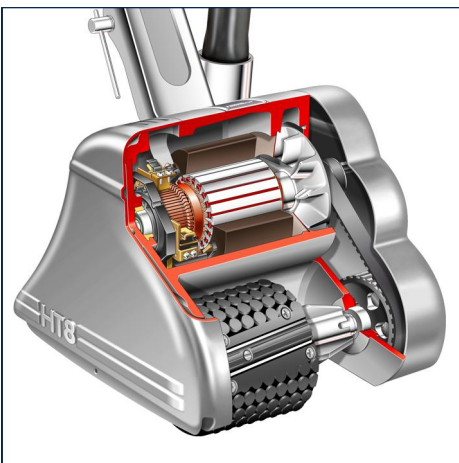

<sup>1</sup> Patents: UK2360723, US6439985 other patents pending.



The HT8 motor is a high speed, universal, continuous heavy duty, self cooling four brush design. It will not stall or slow down under load when sanding with coarse grit abrasives, removing old surface finishes, deposits of wax or dirt. This high performance ensures a fast, consistent production rate making it easy for the user to get a regular and uniform finish across the whole floor area and throughout the complete range of abrasive grits.

The design of the motor, as used in all Hiretech floor sanders, means the motor provides varying levels of power depending on load - ideal for floor sanding. The HT8 motor will deliver up to 4.5hp, depending on load, yet can be powered through any standard domestic supply without nuisance tripping or blowing fuses.

Simple maintenance routines keep the HT8 in service, ready for use minimising downtime. The multi-speed control provides the workshop technician with an easy to understand sequence of lights that show run-time at 300hrs and 100hr intervals prompting motor and other timed service routines. After these routine service tasks have been completed the run-time is easily reset.



### Upgrade to the HT8 Multi-Speed

The HT8 Multi-Speed control is available for upgrading any age HT8 or DU8 floor sander - simply plug and go. The upgrade kit includes a complete new handle assembly with multi-speed control, new Owners Manual and Operating Instructions, user instructions and workshop service information. Contact your local reseller for information or visit our website at [www.hiretech.biz/multi-speed/upgrade.html](http://www.hiretech.biz/multi-speed/upgrade.html).



### HT8 Multi-Speed Abrasive & Speed Application Chart

For detailed abrasive and speed application data see page 20.

Abrasive Grit	Application	Speed Setting			
		1	2	3	4
Extra Coarse P16 to P24	For heavy sanding, stripping and levelling of floors in poor condition, fast stock removal, removal of heavy deposits of wax and dirt.			✓	✓
Coarse P30 to P50	For general sanding, stripping and levelling of floors in poor to average condition, levelling of most floor types. In progression from extra coarse grit abrasives.		✓	✓	✓
Medium P60 to P80	Light sanding and stripping of floors in average condition. First sanding of floors previously sanded in need of renovation. In progression from coarse grit abrasives.	✓	✓	✓	✓
Fine P100 to P120	Fine sanding for floors in good condition in need of maintenance. For progression to final sanding from medium grit abrasives. For progression to extra fine sanding with an orbital floor sander.	✓	✓	✓	✓

